

Please read the manual before using the product. The manual and carton contain important information, please keep them properly for later references. If failure to following the instruction in the manual, it might be dangerous for your child.

In order to improve the product and quality, we may change the parts of structure, appearance, packing method, assembly method and function of the product without any notice. When there is any difference between the manual and the product, please subject to the actual product. We are sorry for any inconvenience.



The assembly manual of
battery operated car

Model: SX1919

Executive standard :

EN71-1

EN71-2

EN71-3











EN62115

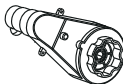

WARNING:

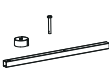
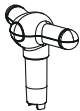
Products should be assembled by an adult. Protective equipment should be worn. Not to be used in traffic. Not suitable for children under 3 years. Choking hazard- small parts. In unassembled state, contains potentially hazardous small parts. Please keep out of the reach of small children. Pay attention to the potential hazards of using the toy in areas other than private grounds.

PARTS LIST

PARTS NAME	PICTURE	QTY	PARTS NAME	PICTURE	QTY
Car body		1PC	Steering wheel		1PC
Front wheel		2PCS	Rear wheel		2PCS 4PCS(optional) 6PCS(optional)
Motor		2PCS 4PCS (optional) 6PCS (optional)	Rear axle		1PC 2PCS(optional) 3PCS(optional)
Trailer		0PC (optional) 1PC (optional) 2PCS (optional)	Trailer connection parts		1PC (optional) 2PCS (optional)
Trailer handrail		1PC (optional) 2PCS (optional)	Charger		1PC
Hardware package		1PC	User manual		1PC

Disclaimer:

The pictures in this instruction are for assembly reference only. Please refer to the actual product.

WARNING:

This product is not the vehicle for transportation, it should be used under adult guidance. Parents should ensure that children have taken the safety measures before use. The toy should be used with caution since skill is required to avoid falls or collisions causing injury to the user or third parties.

PRODUCT SPECIFICATIONS

Battery	6V-4.5AH/12V-7AH/12V-10AH/12V-14AH
Main material	PP
Suitable age	37-95 Months
Weight limit	60kg
Product size	(900+497+497)X380X545.5mm
Speed	3-5KM/Hour
Runtime	1-2 hours after charging for 8-12 hours, based on ride on conditions
Charger	Input AC 110-240V Output DC 12V-1000mA
Fuse	Auto-reset fuse

Parent-child function

Put the seat inside the trailer, child can sit on it, turn over the seat, parent can seat and play with child together.

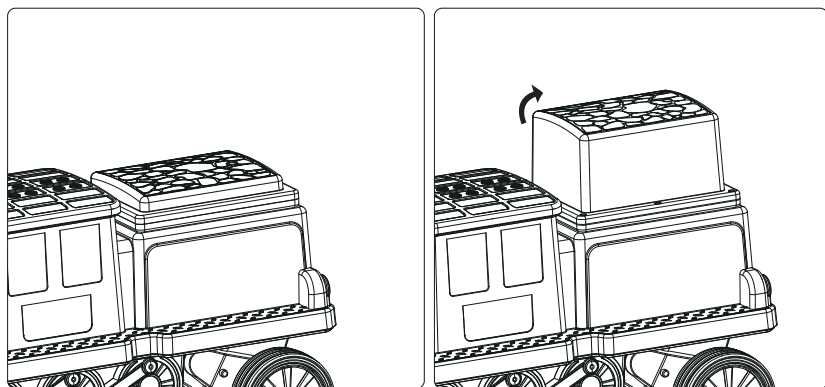

Trailer can store battery

Pull the cover of the trailer upward and remove the cover, spare battery can be put inside. Then take the cover back.

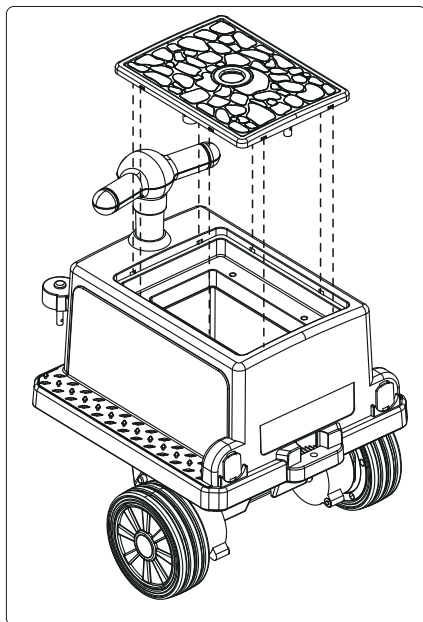
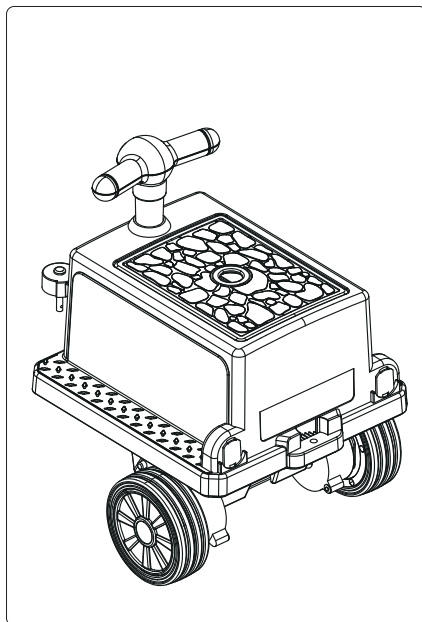

Quick release seat plate, convenient maintenance

Unscrew the screws on the side of the red seat plate, remove the plate, it is convenient for internal electrical maintenance.

Assembly instruction

Car assembling should be done by the adults.

Take care of small parts. To avoid choking hazard, keep children away while assembling. Children under 36 months are prohibited to use.

Please count all the parts carefully before assembling and dispose the plastic bag properly. To avoid choking hazard, children are not allowed to play with the bag.

1. Front wheel assembly

Turn over the car body, insert a washer and the front wheel to front axle, fix with washer, cotter pin and wheel cover.

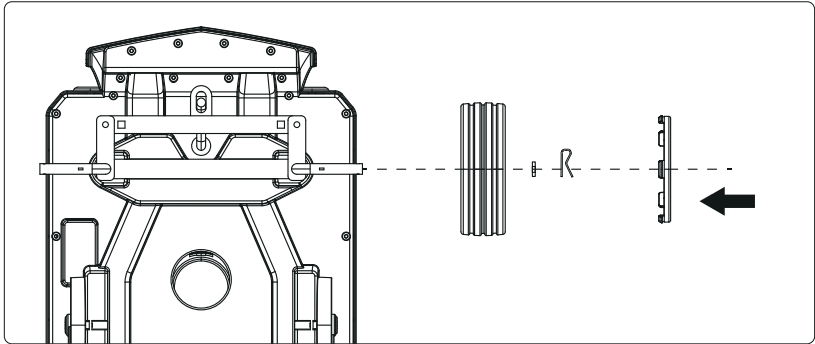

2. Rear wheel assembly

a. First, check whether the rear axle is in the middle of the car, make sure the axle length that extend out on both sides are same.

b. Attach the rear wheel to the rear axle and motor, fixed with washer, cotter pin and wheel cover.

c. Turn over the car body, make sure that the assembled wheel is contact with the ground, pull out the rear axle until it can't move, then assembly another wheel.

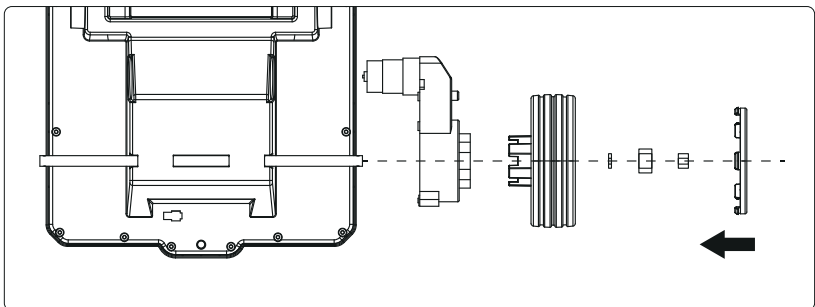

3. Steering axle assembly

Connect steering wheel wire to the wires coming out of the steering column and match connectors. Insert the steering wheel into the steering column, fix with a screw and a nut.

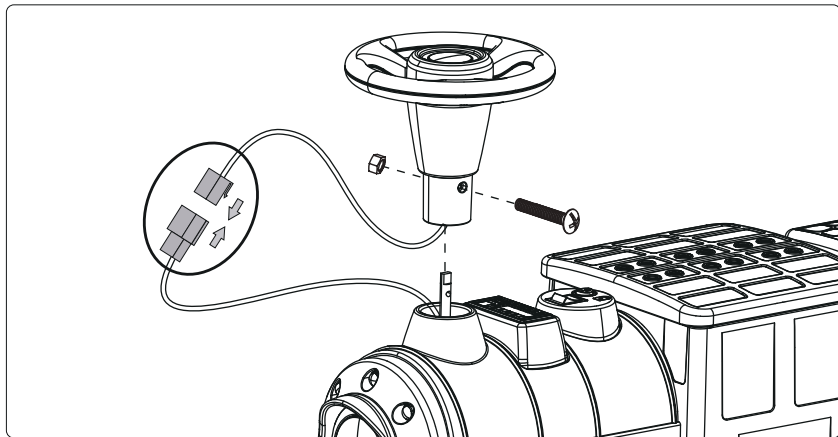

4. Battery connection

Battery is located under the red seat plate, unscrew the screws on the side of the seat, press down the button and remove the seat plate, you can see the battery, insert the protective device to the red plug which is fix on the car body, now battery is connected. Removable battery is optional, release battery lock and take out the battery to charge.

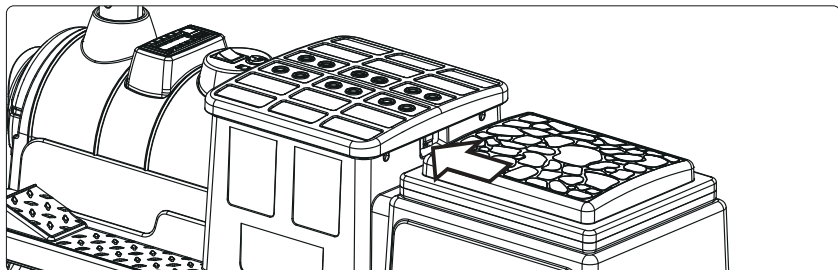

A. Non-removable battery connection

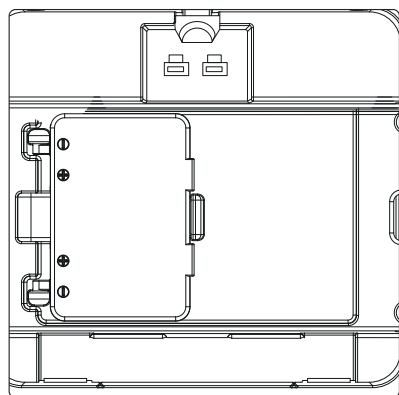

protective device

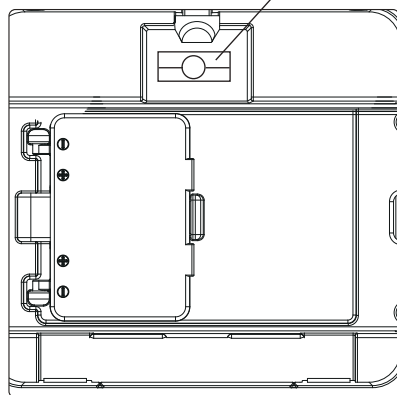

B. Removable battery connection (optional)

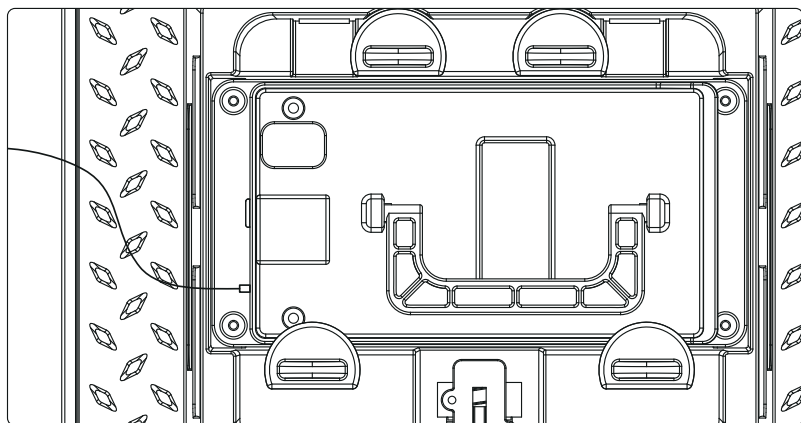

Attention: The following trailer is the optional specification, please assemble as the type you purchased.

5. Trailer assembly

Turn over the trailer, insert the axle to the trailer, attach the motor and wheel to the axle, fix with washer, cotton pin and wheel cover.

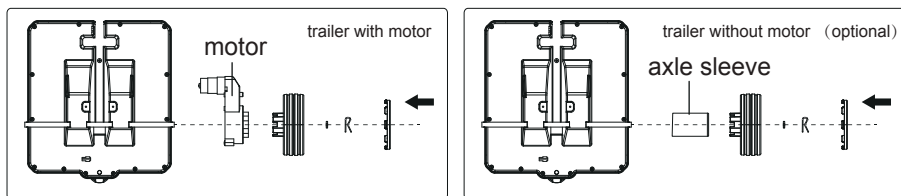

6. Trailer and locomotive assembly

Fix the trailer connection iron part under the trailer, then turn over trailer, attache the trailer with the locomotive, insert the screw and fix with washer and cotton pin. Connect the plugs from trailer and locomotive.

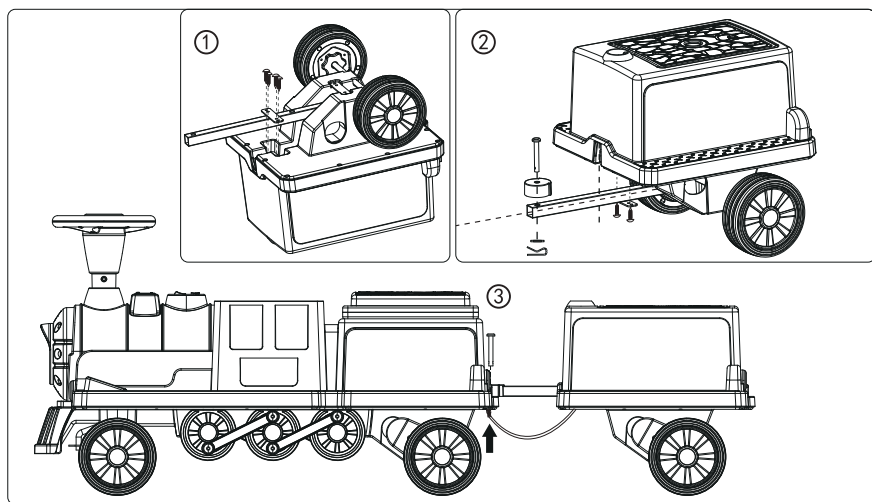

7. Trailer handrail assembly

Insert the trailer handrail to the corresponding openings, push it into place.

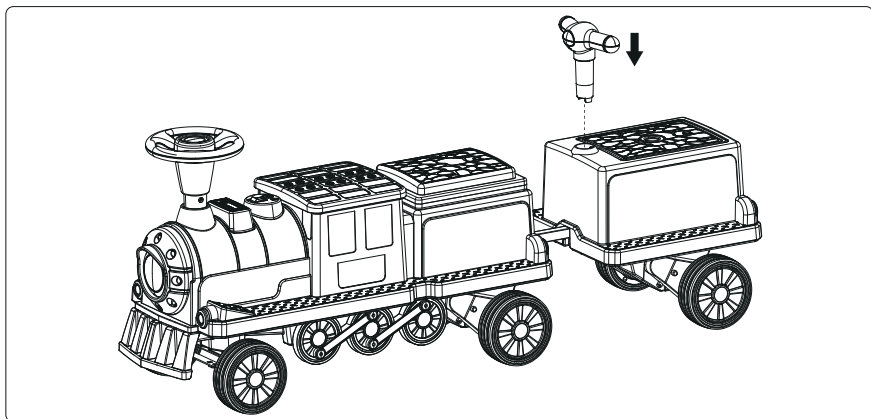

The installation steps are same if the product has two trailers.

FUSE

This car has a auto-reset fuse, if the car stops suddenly during driving, it is mainly caused by instantaneous current exceeds ,which makes the fuse to trip. Then just stop operating for about 8 seconds, and this fuse can be reset. In order to avoid the fuse tripping and cutting off power supply, please pay attention to the following matters.

This product can't be overloaded, the maximum load is 100kgs.

Don't drag anything behind the product.

Don't let the warter or other liquid into the batteries and other electrical components.

Don't change the circuit system and structure of the product.

CIRCUIT DIAGRAM

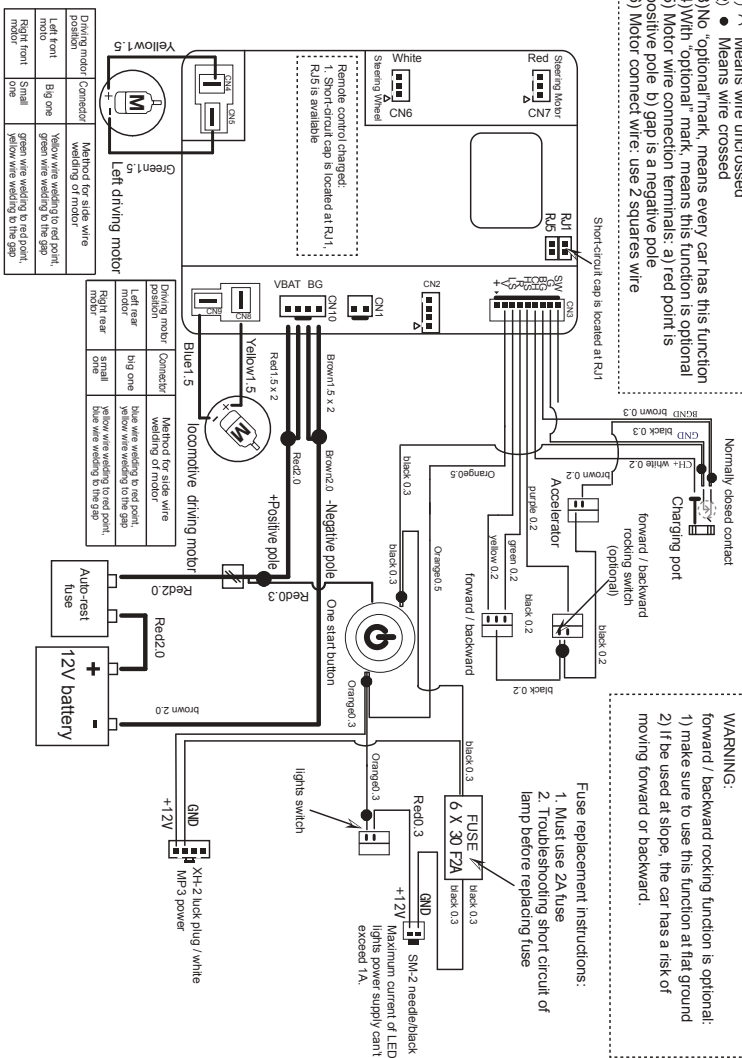

SECURITY WARNING

- 1.The installation and charging of vehicle should be under adult supervision at all times.
- 2.This product is limited to the children from 37 to 95 months, 100 kg weight limit, please do not overload.
- 3.This product is ideal for driving on a hard flat surface.
- 4.It is strictly prohibited in the streets or the road, pot holes, and slopes.
- 5.Avoid driving in the sand or grass or uneven ground.
- 6.Children should be given full instructions on operation of the car. Improper operation can cause damage or accidents.
- 7.While children are driving, it is parents' duty to supervise at all time to avoid accidents.
- 8.Avoid driving in rains or flooded pathways. By doing so it can damage the motor, circuit and other electrical equipments.
- 9.Battery charger should be regularly inspected by parents to insure that the wires, plugs, crusts and other components are not damaged. Please stop using if any damage is found, until it is completely restored.
- 10.In order to ensure product life and safety, avoid damage to the charger, battery or electric circuit, the car must use the default configuration of a dedicated charger and power supply.
- 11.Rechargeable batteries should be removed from the toy before charging.
- 12.When no use of product, please cut off the product power, and keep all the switch to "stop" or "off" position.
- 13.The charger provided is not a toy. It is to be kept away from children.
- 14.Strictly prohibit using the non-manufacturer provided parts.
- 15.This product is made of PP material mainly, and the safe using time is two years.

USAGE DIRECTION

1. Before using it, make sure that all the following works are done.
 - Step described in accordance with the instructions to complete the installation of the car, the battery plug-in has been connected, the power supply has been switched on.
 - Make sure that all the positions which need the screws are fixed tightly.
 - Parents or guardian should ensure that children have taken the safety measures before using.

To reduce the risk during using, pay attention the followings: When driving the car ,child should sit on the car seat.

Adult or parents should take more care and guidance when child driving and can't leave away.

Pay attention to the driving environment and driving on the hard flat surface, not the unsafe environment.

For example:

- a.The trenches, the riverside, slope or uneven ground;
- b.Road or other places for driving and walking;
- c.The obstruction which is easily hitting and causing injury;
- d.Other unsafe zones.

To avoid accident, please use only in daytime or bright place, avoid using under low visibility.

WARNING:

When changing the gears, the accelerator should be released and the car has completely come to a stop. Prohibit to change the gear while the car is still moving, because that can damage the wire and other transmission parts.

2. Operating(function reference diagram)

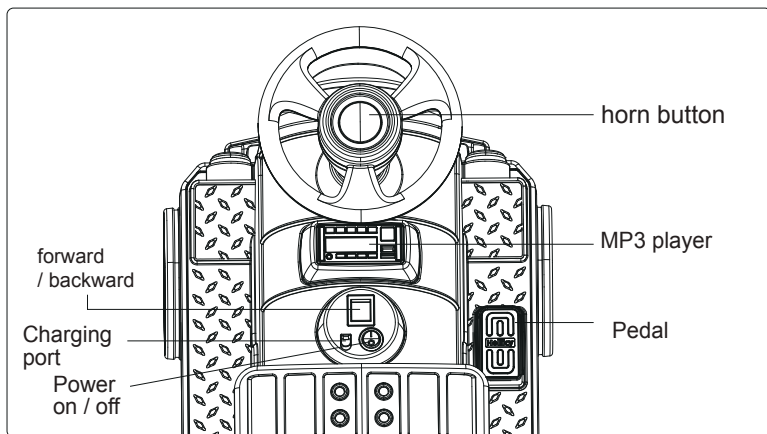

MP3 Optional

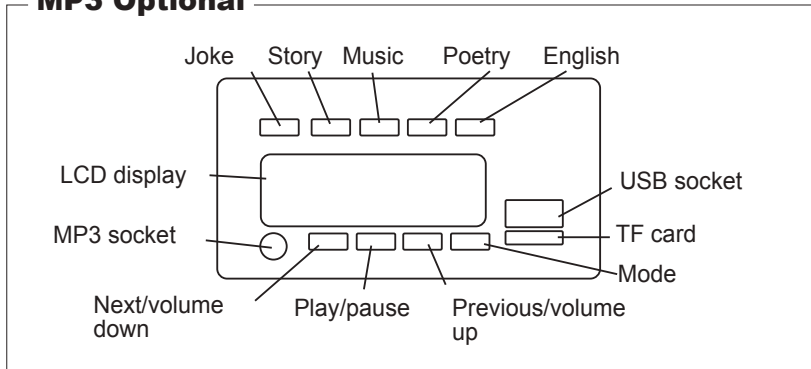

CHARGING WAY

- For Safety purpose ,the charging must be done by adults.
- Charging port is located on the dashboard, please charge the battery as the instructions below.
- If the car has slowed down, it needs to be charged by 8-12 hours, maximum 20 hours.

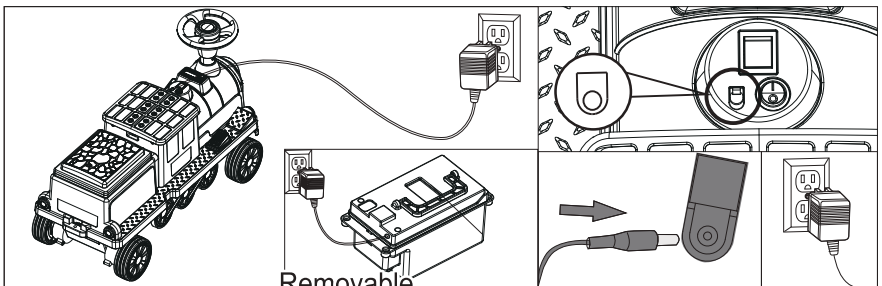

Removable
battery is optional

Attention:

- Can only use the charger and battery according to manufacturers regulations.
- Do not mix old and new or different types of batteries.
- The battery terminal should not be short circuit.
- Do not open the battery or charger.
- Do not reverse the battery.
- Before charging, please check whether the charger, battery and plug are ok, if you find any broken parts, you must stop using it immediately. And do not use it until it is fully repaired.
- The battery will be little warm when being charged, it is normal. If not, it may be caused from the short circuit of charger or circuit board.
- Must use the pressing plate to fix the battery.
- Run out of battery must be handled by adults, remove the battery which has run out from toys to recycle properly and shall not be arbitrarily discard.
- If the product is going to be stored unused long time , it must be fully charged, and charge it every 3 months ,so as to make sure the battery life.
- Charger and Battery are not toys. Keep them away from children.

MAINTENANCE AND SERVICE

- 1, Before use, parents should check whether all parts like batteries, charger, wires, plug, outer body and other parts are in good condition, check whether the screws are loose and whether there are potential safety hazards. Any damaged parts founded should be repaired before using.
- 2, After using the product for a period of time, use a small amount of lubricating oil to the moving parts to prevent wear and tear of rust.
- 3, Keep the car away from fire and direct sunlight. Place it stably, not upside down. The car shall be stored indoors or outdoors under cover.
- 4, The car should be kept away from hot items, such as stoves or heaters, or the plastic parts will melt. When charging, the car should be kept away from inflammable materials to prevent it from catching fire.
- 5, Charge in time after use. Charging should be done by adults. If the product is going to be unused for a long time, it must be fully charged. Charge it every month so as to extend the battery lifespan.

6, A soft cloth must be used to clean the car. Do not use chemical solvents to clean the plastic parts. Do not use soap or water to clean the car. Driving in rainy or snowy weather, water can damage the motor, battery and circuit system.

7, When stopping or storing the car, please cut off the power and make sure all switches are in the 'STOP' or 'OFF' position.

8, Do not use fuses different from the specifications of this product.

9, Do not change the product structure and circuit system. Maintenance and repair work must be done under the guidance of the professional or technical personnel in place.

10, Do not use the product for other purposes. Put the battery in the right polarity.

11, Battery negative short circuit is prohibited. Non-rechargeable batteries cannot be charged.

12, Rechargeable batteries can only be charged under the supervision of the adult.

13, Do not mix old and new batteries or different types of batteries.

14, The battery running out of power should be removed from the car properly and not allowed to be played by children.

15, Disconnect the batteries completely when not in use and do not allow children to play with them.

TROUBLESHOOTING

Car does not move or power on	If "power" switch is in OFF position
	If the battery is not connected, check the red and black wires.
	If the charger is plugged in, car will not power on. Unplug charger.
	If the pedal switch is not functioning properly
	If the wheels stuck and cannot move
Car moves slowly	If the battery is not fully charged. Need to be charged in time
	If there is an issue with the wheels
	If rider weight exceeds specifications
Battery does not charge	If the charger is malfunctioning
	If the battery lost its capacity
	If the charger and battery connection are charged

PINGHU SHUANGXI BABY CARRIER MANUFACTURE CO.,LTD.
PINGHU BABY CARRIER INDUSTRY CITY, ZHEJIANG, CHINA
